

ITEM NO.	PART NUMBER	QTY.
1	NEW Bridge Tall Part 2	2
2	NEW BRIDGE Assem Lift Gate	1
3	NEW Bridge Front Face	2
4	Road for base	2
5	Decorative Finishing Nail 1x10	9
6	Back Portion TOP	2
7	Back Portion MID	2
8	Top Brick	2
9	ElectronicsAssem	1
10	Counter Weight Main Body	2
11	ElectronicsAssemRH	1

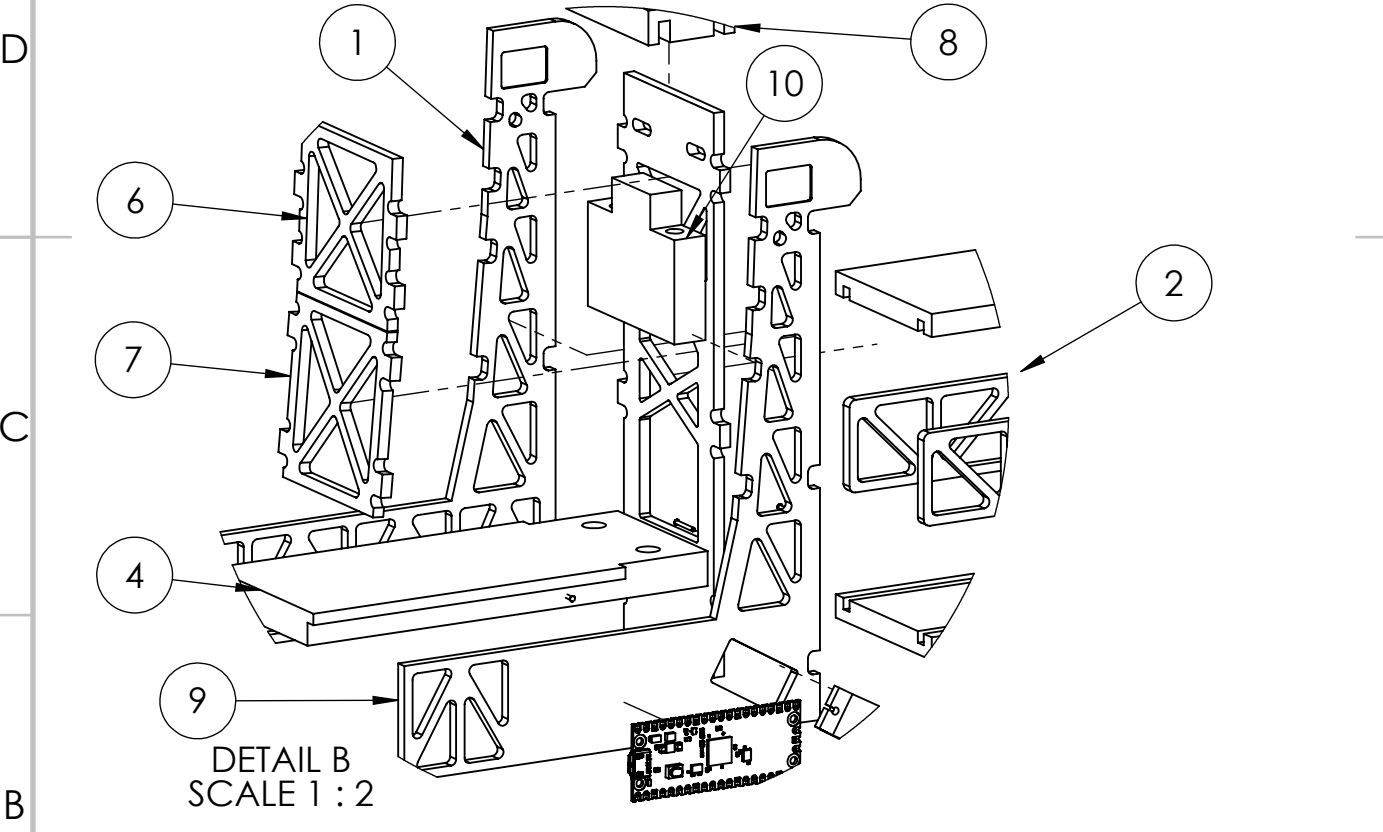

UNLESS OTHERWISE SPECIFIED:
 DIMENSIONS ARE IN MILLIMETERS
 SURFACE FINISH:
 TOLERANCES:
 LINEAR:
 ANGULAR:

FINISH:
 CHISEL CORNERS SHARP
 AS NEEDED, SAND BURS

DEBURR AND
 BREAK SHARP
 EDGES

DO NOT SCALE DRAWING REVISION A

MTU MAKERSPACE

NAME	SIGNATURE	DATE
DRAWN SAV	SAV	9/28/2021
CHK'D SAV	SAV	10/11/21
APPV'D CDL	CDL	10/11/21
MFG LAC	LAC	10/14/21
Q.A SAV	SAV	10/11/21

TITLE:
 NEW BRIDGE
 ASSEM TOP

DWG NO. PB-0 A4

WEIGHT:

SCALE:1:10

SHEET 1 OF 1

REV.	DESCRIPTION	DATE
A	RELEASED FOR PRODUCTION	10/22/2021
B	REMOVED SIDE TABS AS WELL AS TOP/BOTTOM TABS	10/22/2021

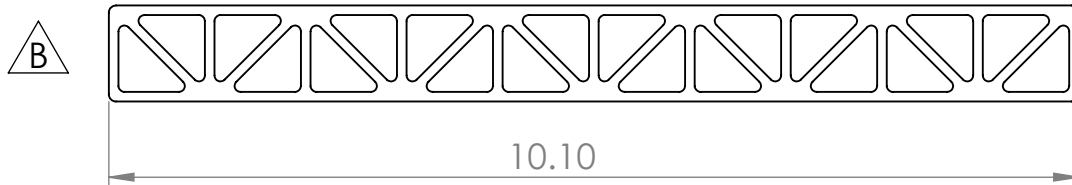

UNLESS OTHERWISE SPECIFIED:
 DIMENSIONS ARE IN MILLIMETERS
 SURFACE FINISH:
 TOLERANCES:
 LINEAR:
 ANGULAR:

FINISH:
 SAND, THEN PAINT PER
 BRIDGE COLORS IF NECC.

DEBURR AND
 BREAK SHARP
 EDGES

DO NOT SCALE DRAWING

REVISION A

NAME	SIGNATURE	DATE
DRAWN SAV		9/28/21
CHK'D		
APPV'D		
MFG		
Q.A		

TITLE:
NEW LIFT GATE SIDES

MATERIAL:
 MDF, OR HARD 1/8 PLYWD

DWG NO.
BP-1

A4

WEIGHT:

SCALE:1:5

SHEET 1 OF 1

REV.	DESCRIPTION	DATE
A	RELEASED FOR PRODUCTION	10/22/2021
B	REMOVED TAB CUTOUTS, CHANGED DISTANCE FROM SIDE TO SLOT FROM 0.13 TO 0.17	10/22/2021

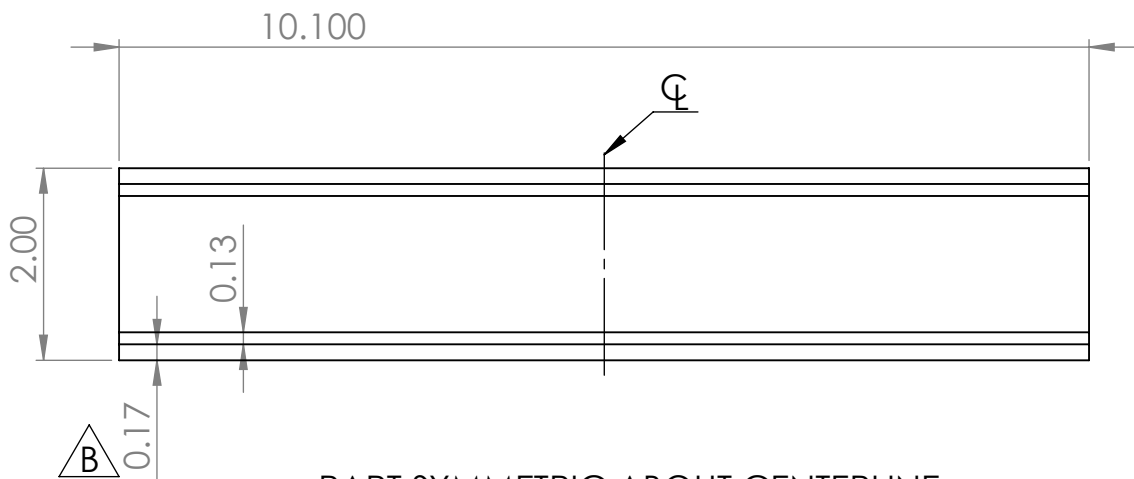
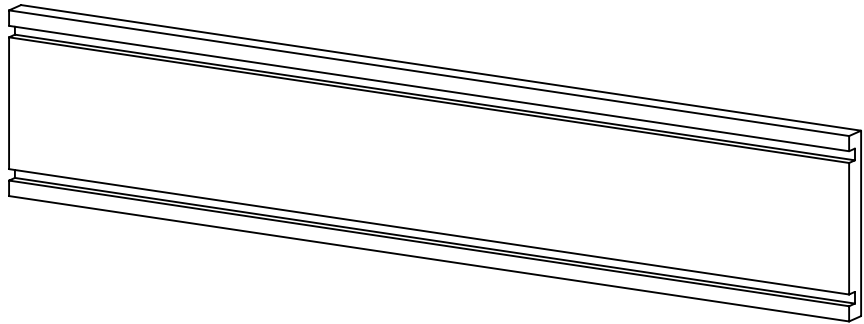

PART SYMMETRIC ABOUT CENTERLINE

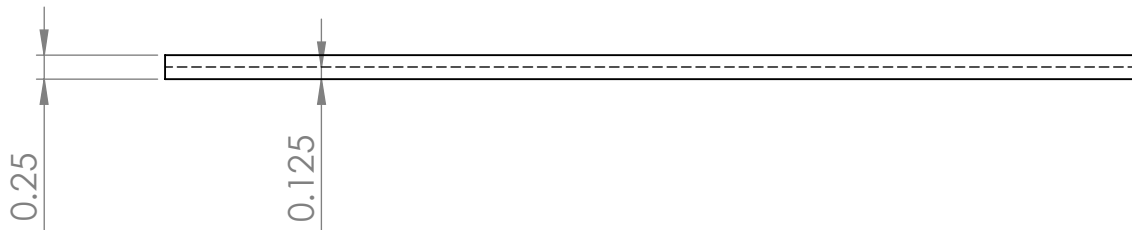

UNLESS OTHERWISE SPECIFIED:
DIMENSIONS ARE IN MILLIMETERS
SURFACE FINISH:
TOLERANCES: +0.01, -0.00
LINEAR:
ANGULAR:

FINISH:

DEBURR AND
BREAK SHARP
EDGES

DO NOT SCALE DRAWING

REVISION

A

	NAME	SIGNATURE	DATE
DRAWN	SAV		9/28/21
CHK'D			
APPV'D			
MFG			
Q.A			

TITLE:

NEW LIFT GATE
TOP-BOTTOM

MATERIAL:

DWG NO.

BP-2

A4

WEIGHT:

SCALE:1:5

SHEET 1 OF 1

4 3 2 1

REVISIONS

REV.	DESCRIPTION	DATE	APPROVED
A	RELEASED FOR PRODUCTION	10/22/2021	SAV
B	MODIFIED TAB DEPTH TO 0.145 FROM 0.125, CHANGED RADII TO 0.0625 FROM 0.3125	10/22/2021	

F

F

E

E

D

D

C

C

B

B

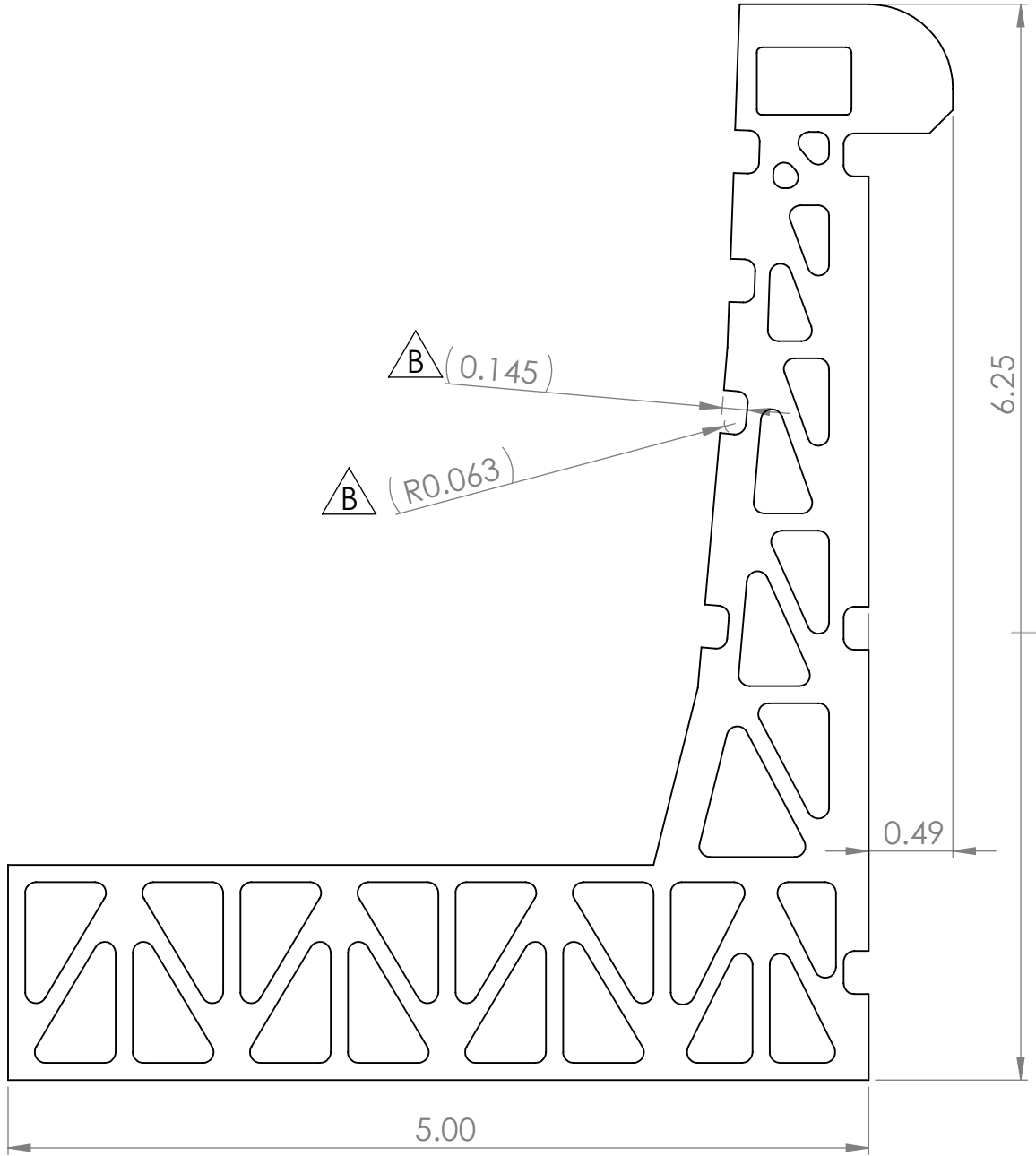

UNLESS OTHERWISE SPECIFIED:
DIMENSIONS ARE IN MILLIMETERS
SURFACE FINISH:
TOLERANCES:
LINEAR:
ANGULAR:

FINISH:

DEBURR AND
BREAK SHARP
EDGES

DO NOT SCALE DRAWING

REVISION B

NAME	SIGNATURE	DATE
DRAWN SAV		9/28/2021
CHK'D		
APPV'D		
MFG		
Q.A		

TITLE:
BRIDGE SIDES NO ELEC.

MATERIAL:
1/8" MDF OR PLYWD

DWG NO.
BP-3

SCALE:1:2

SHEET 1 OF 1

A

A

4 3 2 1

4 3 2 1

REVISIONS		
REV.	DESCRIPTION	DATE
A	RELEASED FOR PRODUCTION	10/22/2021
B	REMOVED SLOTS FOR MIDDLE ASSEM	10/22/2021

F

F

E

E

D

D

C

C

B

B

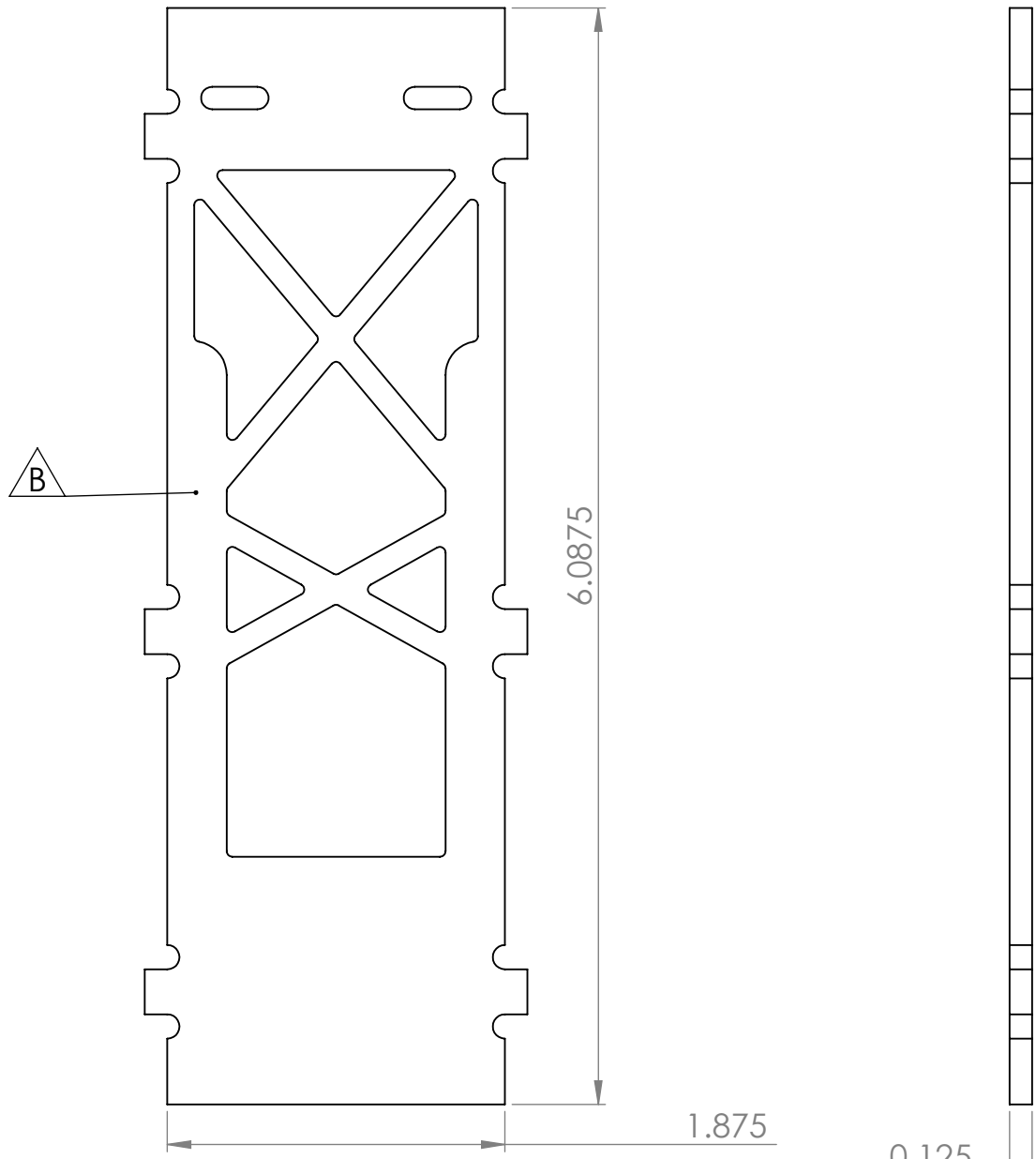

UNLESS OTHERWISE SPECIFIED:
 DIMENSIONS ARE IN MILLIMETERS
 SURFACE FINISH:
 TOLERANCES:
 LINEAR:
 ANGULAR:

FINISH:

DEBURR AND
 BREAK SHARP
 EDGES

DO NOT SCALE DRAWING

REVISION A

NAME	SIGNATURE	DATE
DRAWN SAV		9/28/21
CHK'D		
APPV'D		
MFG		
Q.A		

TITLE:
NEW Bridge Front Face

DWG NO.
BP-4

SCALE:1:2

SHEET 1 OF 1

MATERIAL:

WEIGHT:

A4

4 3 2 1

A

A

REV.	DESCRIPTION	DATE
A	RELEASED FOR PRODUCTION	10/22/2021
B	THREE HOLES ADDED FOR LATCHING MICROSWITCHES, CUTOUT MOVED TO BACK	10/22/2021

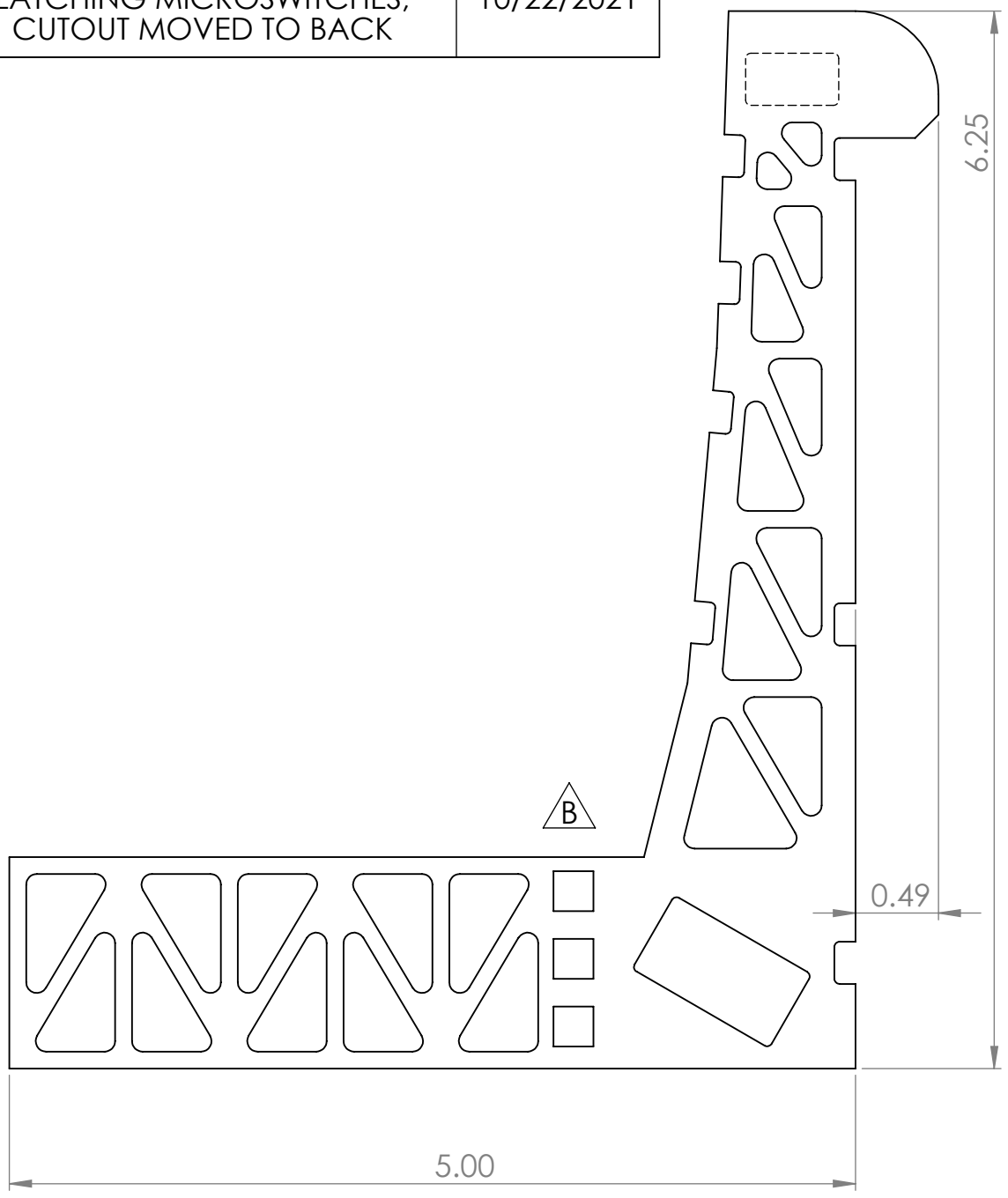

UNLESS OTHERWISE SPECIFIED:
 DIMENSIONS ARE IN MILLIMETERS
 SURFACE FINISH:
 TOLERANCES:
 LINEAR:
 ANGULAR:

FINISH:

DEBURR AND
 BREAK SHARP
 EDGES

DO NOT SCALE DRAWING

REVISION A

NAME	SIGNATURE	DATE
DRAWN SAV		9/28/21
CHK'D		
APPV'D		
MFG		
Q.A		

TITLE:
**NEW BRIDGE TALL PART
 WITH SERVO ONLY**

DWG NO.
BP-5

A4

SCALE:1:2

SHEET 1 OF 1

MATERIAL:
 1/8" MDF OR PLYWD

WEIGHT:

REV.	DESCRIPTION	DATE
A	RELEASED FOR PRODUCTION	10/22/2021
B	2 HOLES ADDED FOR ROUTING SUSPENSION CABLE	10/22/2021

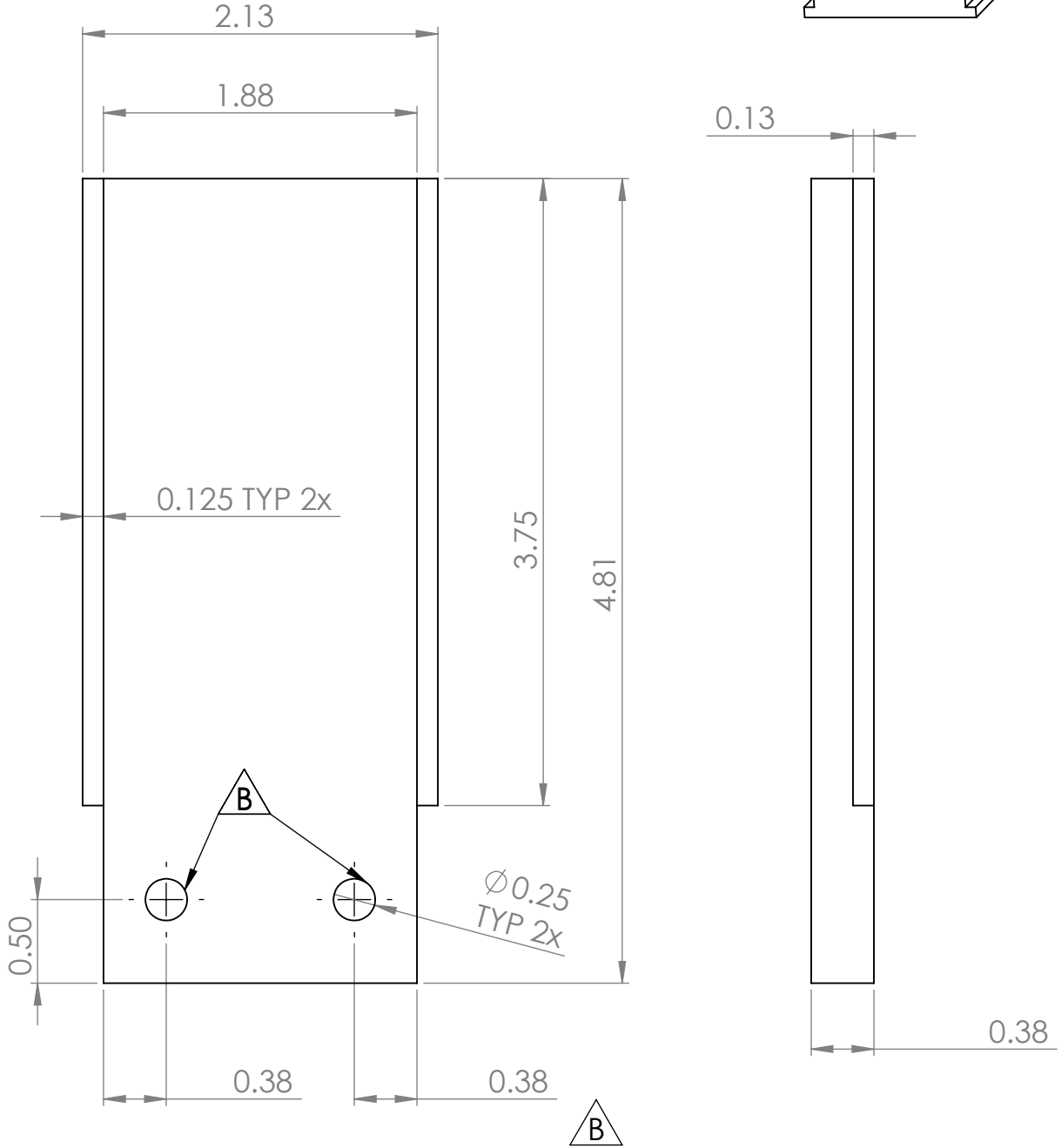
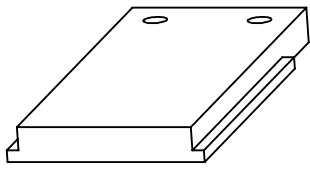

UNLESS OTHERWISE SPECIFIED:
DIMENSIONS ARE IN MILLIMETERS
SURFACE FINISH:
TOLERANCES:
LINEAR:
ANGULAR:

FINISH:

DEBURR AND
BREAK SHARP
EDGES

DO NOT SCALE DRAWING REVISION A

NAME	SIGNATURE	DATE
DRAWN SAV		9/28/21
CHK'D		
APPV'D		
MFG		
Q.A		

TITLE: ROAD FOR BASE

DWG NO. BP-6 A4
SCALE: 1:2 SHEET 1 OF 1

MATERIAL: 3/8 OAK OR HRDWOOD
WEIGHT:

4 3 2 1

F

F

REVISIONS		
REV.	DESCRIPTION	DATE
A	RELEASED FOR PRODUCTION	10/22/2021

E

E

D

D

C

C

B

B

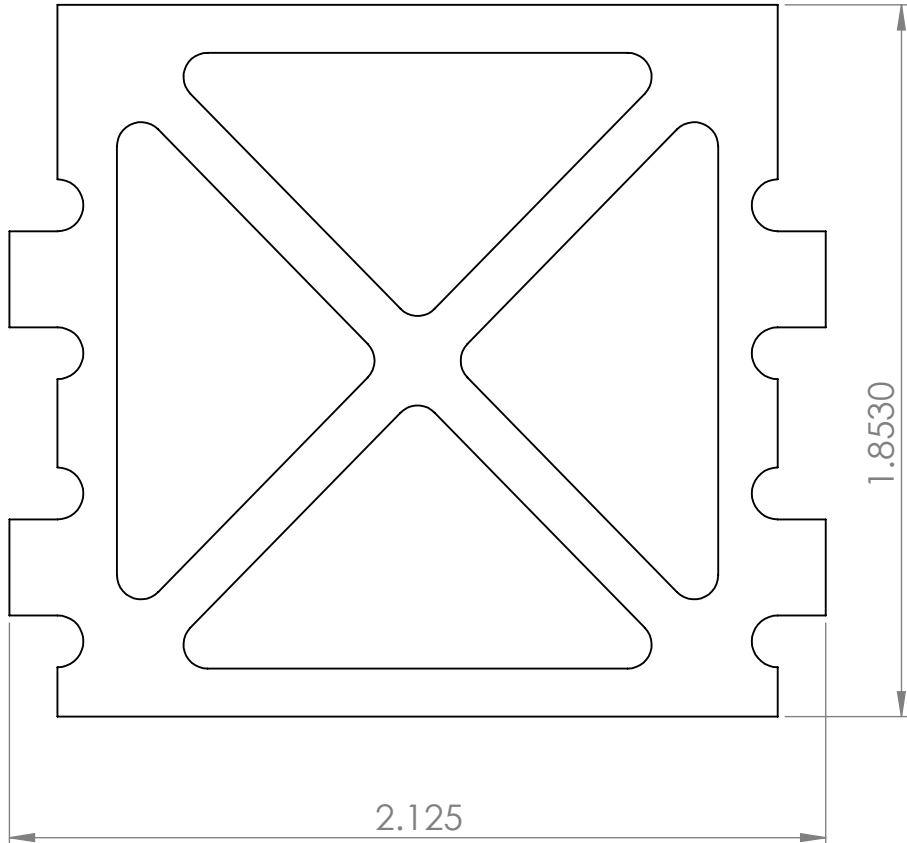

A

A

UNLESS OTHERWISE SPECIFIED:
DIMENSIONS ARE IN MILLIMETERS
SURFACE FINISH:
TOLERANCES:
LINEAR:
ANGULAR:

FINISH:

DEBURR AND
BREAK SHARP
EDGES

DO NOT SCALE DRAWING

REVISION A

	NAME	SIGNATURE	DATE
DRAWN	SAV		9/28/21
CHK'D			
APPV'D			
MFG			
Q.A			

TITLE: **BACK PORTION TOP**

DWG NO. **BP-7**

MATERIAL: **1/8 MDF OR PLYWD**

SCALE: 2:1

SHEET 1 OF 1

A4

4 3 2 1

4 3 2 1

F

F

REVISIONS		
REV.	DESCRIPTION	DATE
A	RELEASED FOR PRODUCTION	10/22/2021

E

E

D

D

C

C

B

B

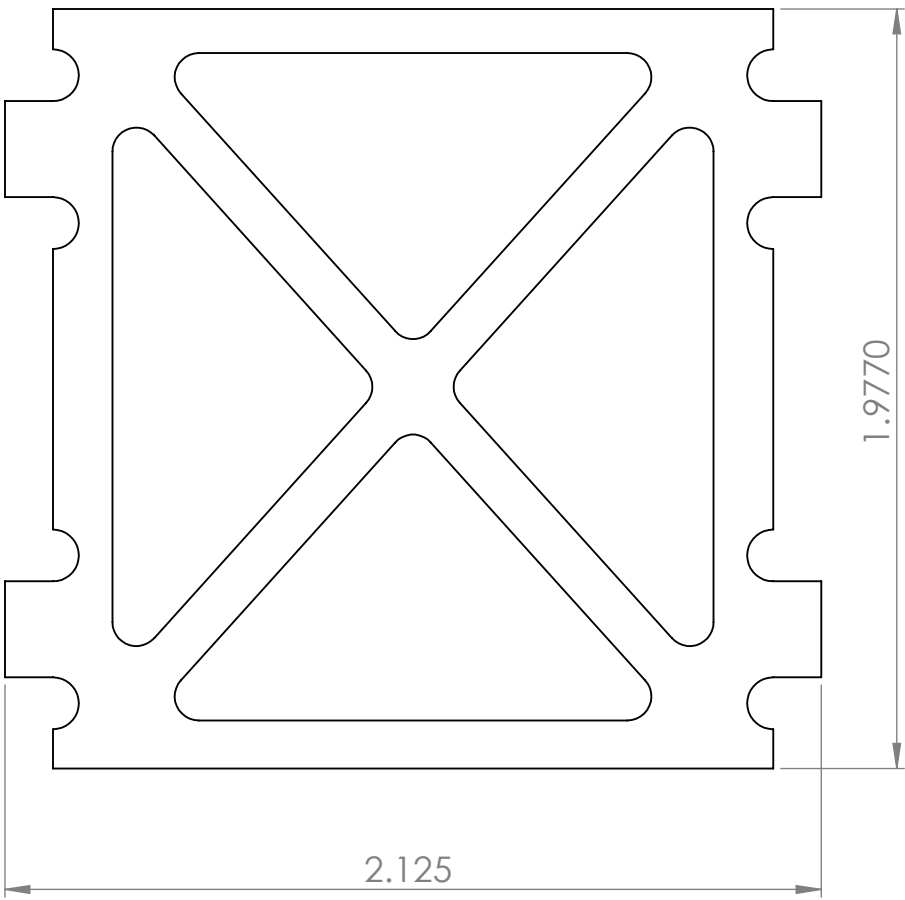

UNLESS OTHERWISE SPECIFIED:
DIMENSIONS ARE IN MILLIMETERS
SURFACE FINISH:
TOLERANCES:
LINEAR:
ANGULAR:

FINISH:

DEBURR AND
BREAK SHARP
EDGES

DO NOT SCALE DRAWING

REVISION A

	NAME	SIGNATURE	DATE
DRAWN	SAV		9/28/21
CHK'D			
APPV'D			
MFG			
Q.A			

TITLE:
**BACK PORTION
MID**

MATERIAL:
1/8 MDF OR PLYWD

DWG NO.
BP-8

SCALE:2:1

SHEET 1 OF 1

A

A

4 3 2 1

4 3 2 1

REV.	DESCRIPTION	DATE
A	RELEASED FOR PRODUCTION	10/22/2021

F

F

E

E

D

D

C

C

B

B

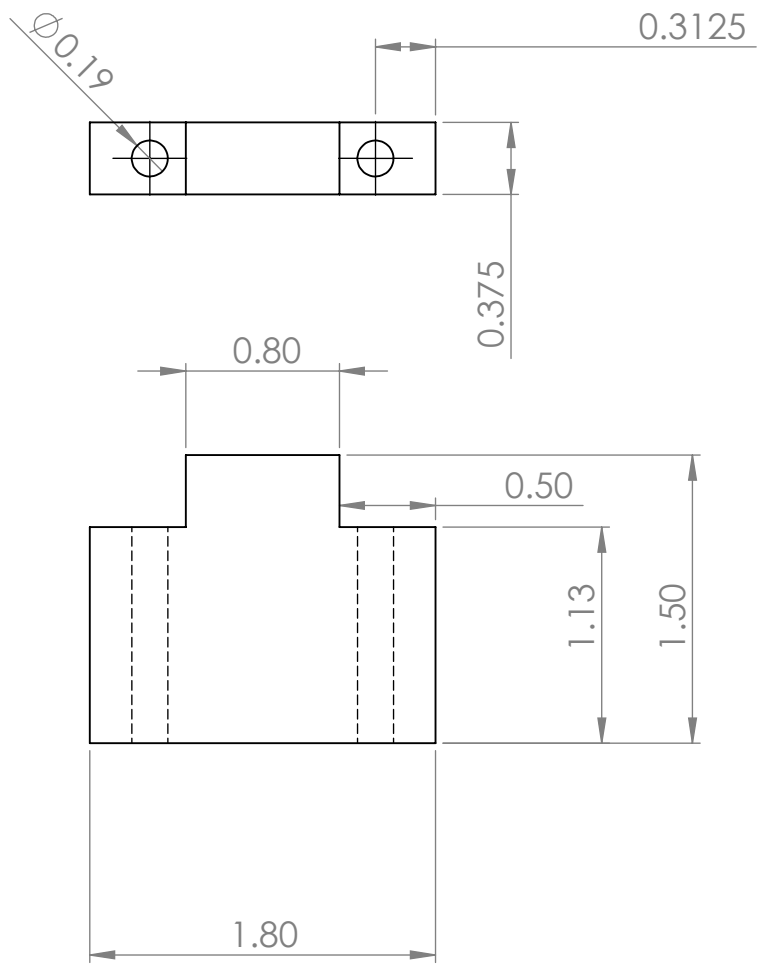

UNLESS OTHERWISE SPECIFIED:
DIMENSIONS ARE IN MILLIMETERS
SURFACE FINISH:
TOLERANCES:
LINEAR:
ANGULAR:

FINISH:

DEBURR AND
BREAK SHARP
EDGES

DO NOT SCALE DRAWING

REVISION A

NAME	SIGNATURE	DATE
DRAWN SAV		9/28/21
CHK'D		
APPV'D		
MFG		
Q.A		
MATERIAL:		
OAK OR OTHER HRDWOOD		
WEIGHT:		

TITLE: **COUNTER WEIGHT MAIN BODY**

DWG NO. **BP-9**

SCALE: 1:1

SHEET 1 OF 1

A4

A

A

4 3 2 1

4 3 2 1

F

REV.	DESCRIPTION	DATE
A	RELEASED FOR PRODUCTION	10/22/2021

F

E

E

D

D

C

C

B

B

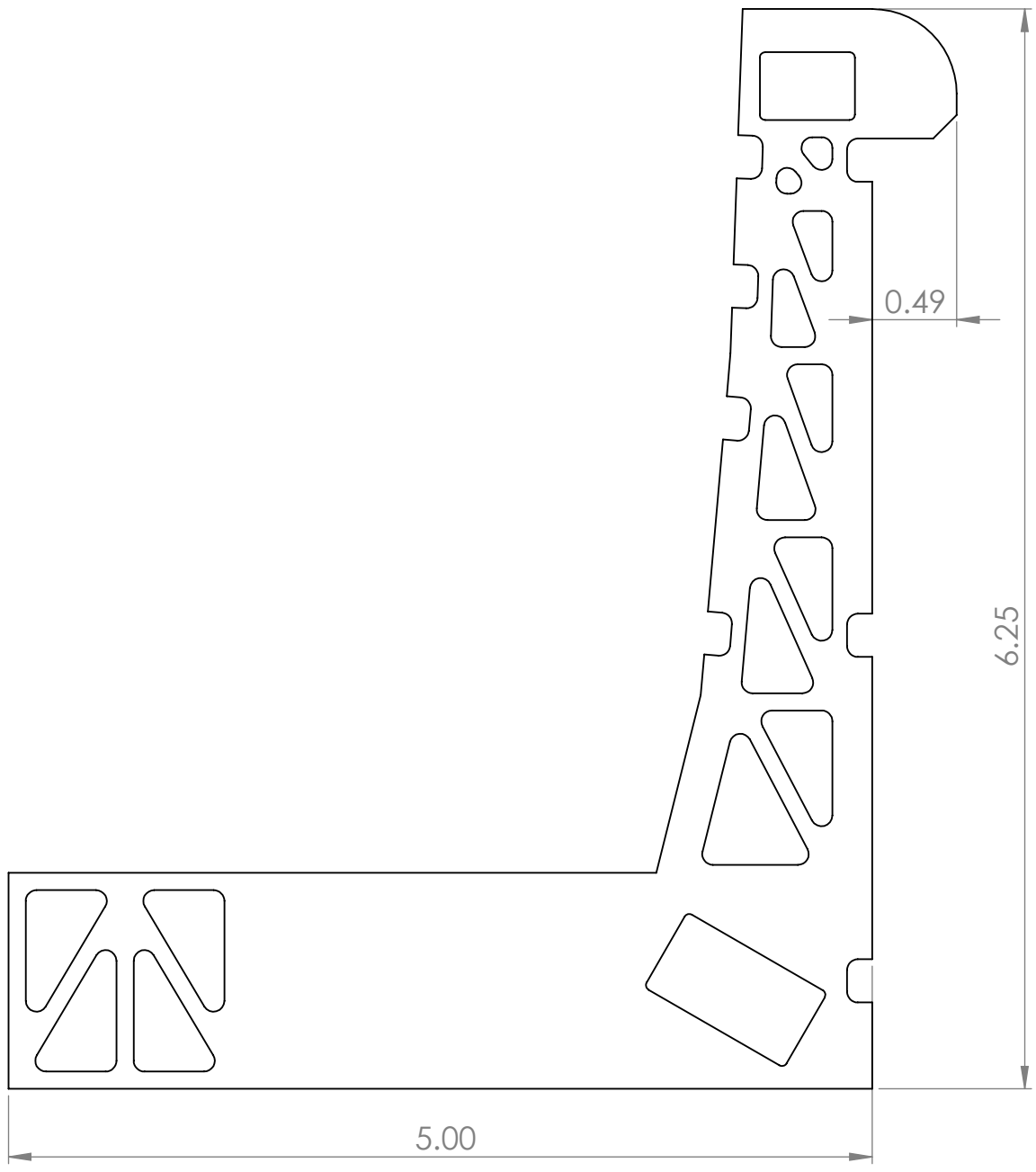

UNLESS OTHERWISE SPECIFIED:
DIMENSIONS ARE IN MILLIMETERS
SURFACE FINISH:
TOLERANCES:
LINEAR:
ANGULAR:

FINISH:

DEBURR AND
BREAK SHARP
EDGES

DO NOT SCALE DRAWING

REVISION A

	NAME	SIGNATURE	DATE
DRAWN	SAV		10/22/21
CHK'D			
APPV'D			
MFG			
Q.A			

TITLE:
**BRIDGE SIDE W/ SERVO
AND CONTROLLER**

DWG NO.
BP-10

SCALE:1:2

SHEET 1 OF 1

A

A

4 3 2 1

REVISIONS		
REV.	DESCRIPTION	DATE
A	RELEASED FOR PRODUCTION	10/22/2021
B	REMOVED 92 DEGREE ANGLE, WIDENED LEFT SLOT TO ACCOMODATE	10/22/2021

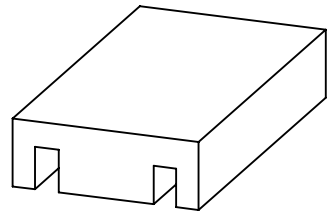
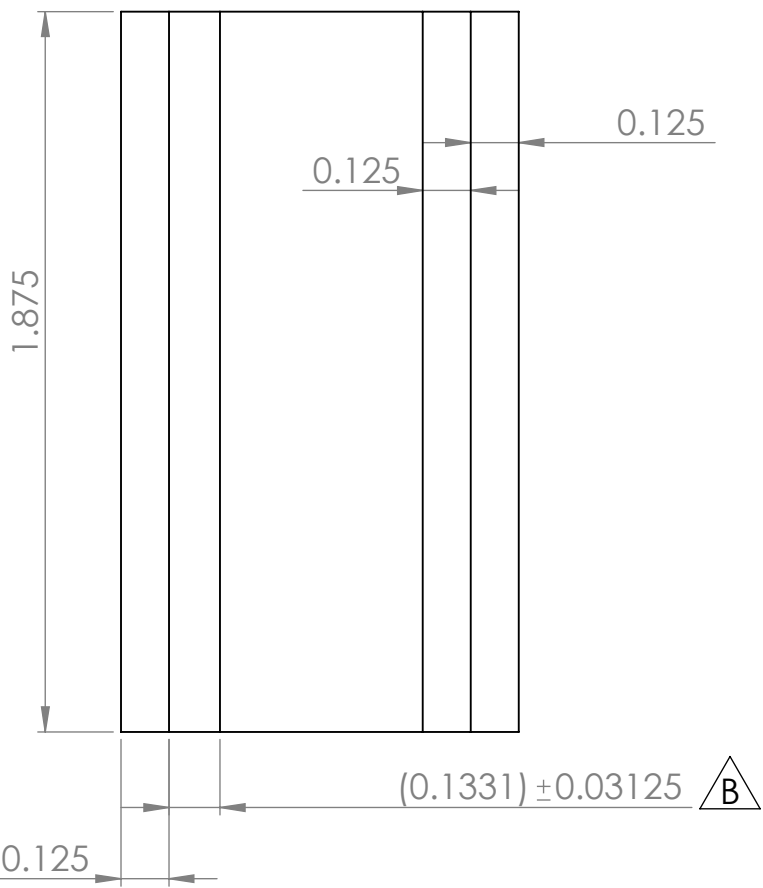
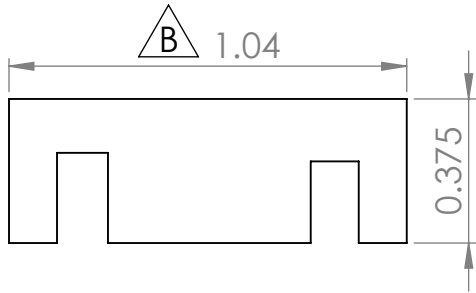

UNLESS OTHERWISE SPECIFIED:
 DIMENSIONS ARE IN MILLIMETERS
 SURFACE FINISH:
 TOLERANCES:
 LINEAR:
 ANGULAR:

FINISH:

DEBURR AND
 BREAK SHARP
 EDGES

DO NOT SCALE DRAWING

REVISION B

NAME	SIGNATURE	DATE
DRAWN		
CHK'D		
APPV'D		
MFG		
Q.A		

TITLE:
TOP BRICK

DWG NO.
BP-11

SCALE:1:1

SHEET 1 OF 1